

SLC Series Spring-Loaded Y-Check Valves

1/2" TO 4" PVC

KEY FEATURES

- Available in PVC
- Full Flow Design
- Closes with No Back Pressure
- Adjustable – Opens From 2 to 15 PSI
- Easy Maintenance
- Opens in Any Position

OPTIONS

- True Union End Connections

MATERIALS

- PVC Cell Class 12454 per ASTM D1784
- FPM and EPDM O-Ring Seals

TECHNICAL INFORMATION

EXPLODED VIEW

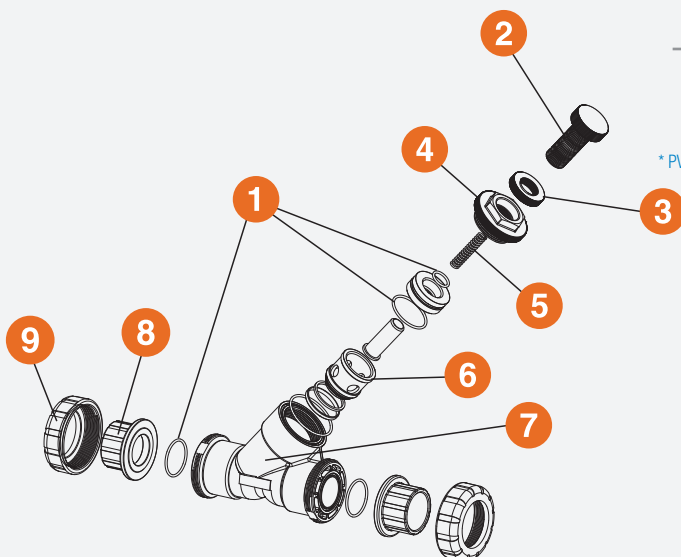

SELECTION CHART

SIZE	MATERIAL	END CONNECTION	SEALS	PRESSURE RATING
1/2" – 4" (DN15 – DN100)	PVC	Socket, Threaded or True Union	FPM or EPDM	150 PSI @ 70°F 10 Bar @ 21°C Non-Shock

* PVC and CPVC socket ends available to ISO 727-1 and threaded ends to BS21.

SLC Series Spring-Loaded Y-Check Valves

1/2" TO 4" PVC

TECHNICAL INFORMATION, CONTINUED

PARTS LIST

1. O-Ring Seal
2. Adjustment Screw
3. Lock Nut
4. Hex Cap
5. Spring
6. Cartridge Assembly
7. Body
8. End Connector (True Union)
9. Assembly Nut (True Union)

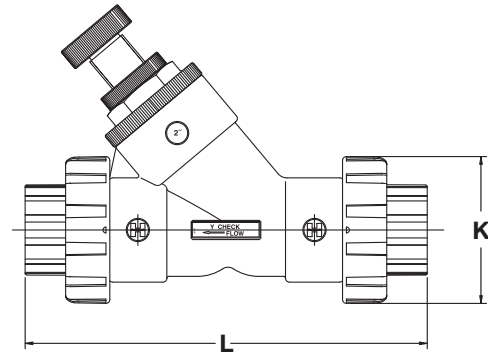
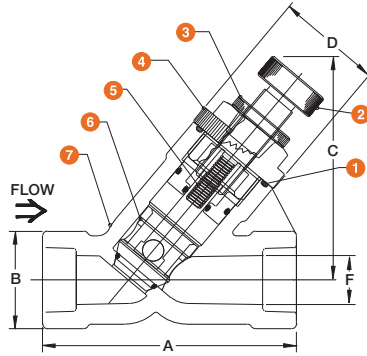

DIMENSIONS

SIZE in / DN	A in / mm	B in / mm	C in / mm	D in / mm	F in / mm	K in / mm	L in / mm	WEIGHT lbs / kg SOC / THD
1/2 / 15	6.19 / 158	2.00 / 51	4.58 / 116	2.13 / 54	1.00 / 25	2.25 / 57	6.64 / 169	0.88 / 0.40
3/4 / 20	6.19 / 158	2.00 / 51	4.58 / 116	2.13 / 54	1.00 / 25	2.63 / 67	7.42 / 188	0.88 / 0.40
1 / 25	5.19 / 132	2.00 / 51	4.58 / 116	2.13 / 54	1.00 / 25	3.00 / 76	8.97 / 228	0.88 / 0.40
1-1/2 / 40	8.63 / 219	3.38 / 86	7.28 / 185	3.75 / 95	2.00 / 51	4.75 / 121	12.07 / 307	3.00 / 1.36
2 / 50	7.63 / 194	3.38 / 86	7.28 / 185	3.75 / 95	2.00 / 51	4.75 / 121	13.05 / 331	3.00 / 1.36
3 / 80	10.31 / 262	4.69 / 119	8.88 / 226	5.25 / 133	2.94 / 75	6.40 / 163	16.77 / 426	7.50 / 3.40
4 / 100	12.75 / 324	5.75 / 146	10.08 / 256	6.00 / 152	3.81 / 97	8.56 / 217	21.23 / 539	9.50 / 4.31

Dimensions are subject to change without notice – consult factory for installation information

TYPICAL APPLICATIONS

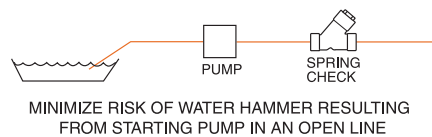
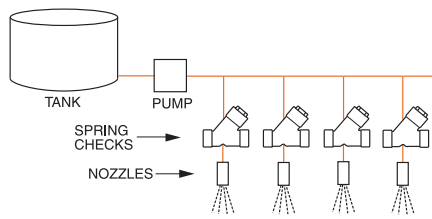
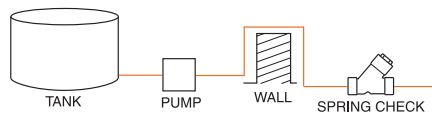

Cv VALUES

SIZE in / DN	Cv VALUES	SIZE in / DN	Cv VALUES
1/2 / 15	0.8	2 / 50	65.0
3/4 / 20	3.0	3 / 80	110.0
1 / 25	9.0	4 / 100	240.0
1-1/2 / 40	45.0		

PRESSURE LOSS CALCULATION FORMULA

$$\Delta P = \left[\frac{Q}{C_v} \right]^2$$

ΔP = Pressure Drop
 Q = Flow in GPM
 C_v = Flow Coefficient

OPERATING TEMPERATURE/PRESSURE

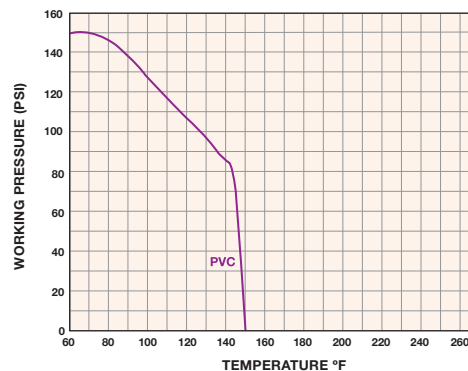

Hayward is a registered trademark of Hayward Industries, Inc. © 2021 Hayward Industries, Inc.

USA: 1.888.429.4635 • Fax: 1.888.778.8410 • One Hayward Industrial Drive • Clemmons, NC 27012 • Email: hfcsales@hayward.com
 Canada: 1.888.238.7665 • Fax: 1.905.829.3636 • 2880 Plymouth Drive • Oakville, ON L6H 5R4 • Email: hflowcanada@hayward.com
 Visit us at: haywardflowcontrol.com