

NEW PRODUCT PREVIEW

TBH Series True Union Ball Valves UHMWHDPE Seats

1/4" TO 2" / DN8 TO DN50 PVC AND CPVC

KEY FEATURES & BENEFITS

- Built with Ultra-High Molecular Weight High Density Polyethylene seats for PFAS Remediation
- No PTFE or related lubricants used in assembly process
- System2™ Sealing Technology provides longer cycle life
- 250 PSI / 16 Bar, non-shock at 70°F / 23°C full pressure rating
- Consistent operating torque with adjustment-free design
- Lockout/Tagout mechanism that secures directly to valve body for enhanced safety
- ISO 5211 mounting flange simplifies actuation
- Permanent markings, eliminates labels
- Integral footpad for skid or panel mount
- FPM or EPDM seals
- Double O-Ring stem seals
- Reversible UHMWHDPE seat design

OPTIONS

- Pneumatic or Electric Actuators
- Stem Extensions
- Manual Limit Switch
- Coupling for Actuator
- HDPE Transition Fittings

MATERIALS

- PVC per ASTM D1784 Cell Class 12454
- CPVC per ASTM D1784 Cell Class 23447
- GFPP per ASTM D4101 Cell Class 85580 (Handle & Lock Plate)

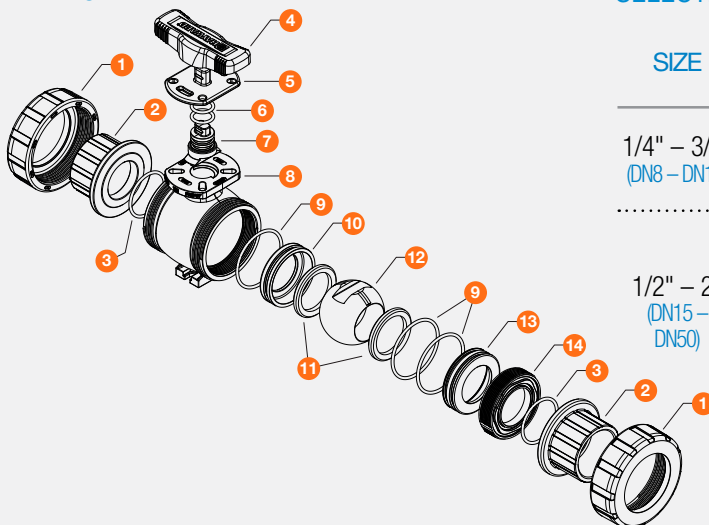
TECHNICAL INFORMATION
EXPLODED VIEW

SELECTION CHART

SIZE	BODY MATERIAL	SEALS	END CONNECTION	PRESSURE RATING
1/4" – 3/8" (DN8 – DN10)	PVC or CPVC	FPM or EPDM	Socket or Threaded	250 PSI @ 70°F 16 Bar @ 21°C Non-Shock
1/2" – 2" (DN15 – DN50)			Socket or Threaded	250 PSI @ 70°F 16 Bar @ 21°C Non-Shock
			Flanged	150 PSI @ 70°F 10 Bar @ 21°C Non-Shock

**All flanged valves are rated to 150 PSI @ 70°F, 10 Bar @ 21°C
 †PVC & CPVC socket ends available to ISO 727-1 / JIS K 6734, threaded ends to BS21 / JIS B 0203 and flanged ends to DIN / EN PN10.
 ‡All Hayward valves, strainers or filters with HDPE end connectors are rated to 150 PSI @ 70°F, 10 Bar @ 21°C

Patented Pat No. 11,131,404, 11,649,899 and Other Patents Pending

TBH SERIES

TRUE UNION BALL VALVES WITH UHMWHDPE SEATS

1/4" TO 2" / DN8 TO DN50 PVC AND CPVC

TECHNICAL INFORMATION, CONTINUED

PARTS LIST / 2D DRAWINGS

1. Nut (2)
2. End Connector (2)
3. End Connector O-Ring (2)
4. Handle
5. Lock Plate
6. Stem O-Rings (2)
7. Stem
8. Body
9. Seat Carrier O-Ring (3)
10. Closed End Seat Carrier
11. Seats (2) - UHMWHDPE
12. Ball
13. Open End Seat Carrier
14. Seat Retainer

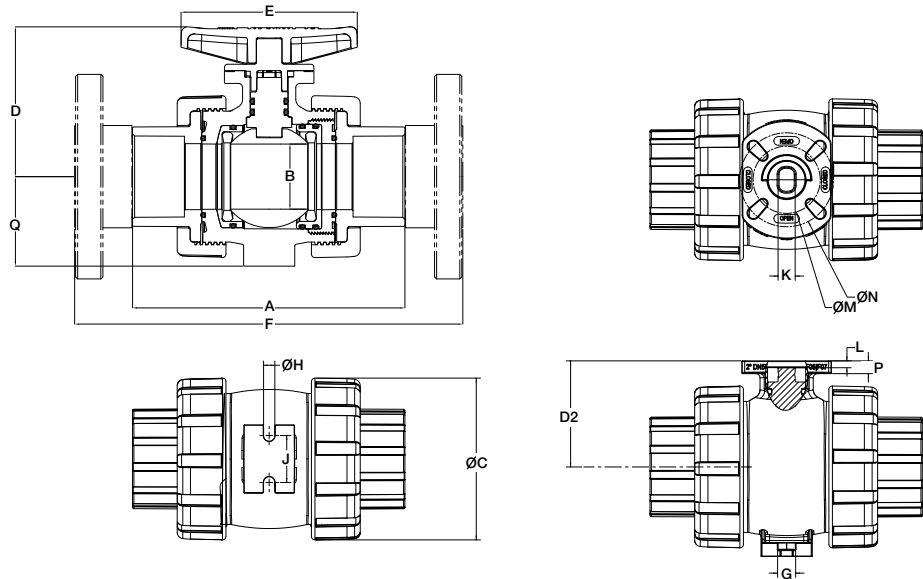

DIMENSIONS – INCHES / MILLIMETERS

SIZE	A	B	C	D1	D2	E	F	G	H	J	K	L	M	N	P	Q
inches / DN	in / mm	in / mm	in / mm	in / mm	in / mm	in / mm	in / mm	in / mm	in / mm	in / mm	in / mm	in / mm	in / mm	in / mm	in / mm	in / mm
1/4 / 8	4.63 / 118	0.53 / 13	2.25 / 57	2.82 / 72	1.75 / 44	3.50 / 89	N/A	0.45 / 11	0.27 / 7	0.75 / 19	0.50 / 13	0.17 / 4	1.97 / 50	N/A	0.29 / 7	1.37 / 35
3/8 / 10	4.63 / 118	0.53 / 13	2.25 / 57	2.82 / 72	1.75 / 44	3.50 / 89	N/A	0.45 / 11	0.27 / 7	0.75 / 19	0.50 / 13	0.17 / 4	1.97 / 50	N/A	0.29 / 7	1.37 / 35
1/2 / 15	4.65 / 118	0.53 / 13	2.25 / 57	2.82 / 72	1.75 / 44	3.50 / 89	6.65 / 169	0.45 / 11	0.27 / 7	0.75 / 19	0.50 / 13	0.17 / 4	1.97 / 50	N/A	0.29 / 7	1.37 / 35
3/4 / 20	4.79 / 122	0.72 / 18	2.62 / 67	2.98 / 76	1.91 / 49	3.50 / 89	7.17 / 182	0.45 / 11	0.27 / 7	0.75 / 19	0.50 / 13	0.17 / 4	1.97 / 50	N/A	0.29 / 7	1.56 / 40
1 / 25	5.34 / 136	0.94 / 24	3.00 / 76	3.25 / 83	2.18 / 55	4.00 / 102	8.05 / 204	0.45 / 11	0.27 / 7	1.00 / 25	0.50 / 13	0.20 / 5	1.97 / 50	N/A	0.29 / 7	1.75 / 44
1-1/4 / 32	6.83 / 173	1.48 / 38	4.00 / 102	3.89 / 99	2.60 / 66	5.17 / 131	9.61 / 244	0.53 / 13	0.33 / 8	1.38 / 35	0.50 / 13	0.20 / 5	1.97 / 50	2.76 / 70	0.34 / 9	2.25 / 57
1-1/2 / 40	7.39 / 188	1.48 / 38	4.00 / 102	3.89 / 99	2.60 / 66	5.17 / 131	10.65 / 271	0.53 / 13	0.33 / 8	1.38 / 35	0.50 / 13	0.20 / 5	1.97 / 50	2.76 / 70	0.34 / 9	2.25 / 57
2 / 50	7.99 / 203	1.91 / 49	4.75 / 121	4.40 / 112	3.11 / 79	5.17 / 131	11.51 / 292	0.53 / 13	0.33 / 8	1.38 / 35	0.50 / 13	0.20 / 5	1.97 / 50	2.76 / 70	0.34 / 9	2.63 / 67

* 1-1/4" and 1-1/2" are 0.56" (14mm) longer than TB Series.

** Dimensions are subject to change without notice - consult factory for installation information.

WEIGHT – LBS / KG

SIZE	Weight with Socket/Threaded Ends	Weight with Flanged Ends	Weight Bare Stem with Socket/Threaded Ends	Weight Bare Stem with Flanged Ends
inches / DN	lbs / kg	lbs / kg	lbs / kg	lbs / kg
1/2 / 15	0.70 / 0.32	1.12 / 0.51	0.59 / 0.27	1.01 / 0.46
3/4 / 20	0.90 / 0.41	1.50 / 0.68	0.79 / 0.36	1.39 / 0.63
1 / 25	1.18 / 0.54	1.98 / 0.90	1.05 / 0.48	1.85 / 0.84
1-1/4 / 32	2.57 / 1.17	3.51 / 1.59	2.32 / 1.05	3.26 / 1.48
1-1/2 / 40	2.62 / 1.19	3.82 / 1.73	2.37 / 1.08	3.57 / 1.62
2 / 50	3.87 / 1.76	6.37 / 2.89	3.62 / 1.64	6.12 / 2.78

CV VALUES

SIZE	Cv VALUES
in / DN	
1/4 / 8	1.0
3/8 / 10	2.8
1/2 / 15	8.0
3/4 / 20	16.0
1 / 25	29.0
1-1/4 / 32	75.0
1-1/2 / 40	90.0
2 / 50	150.0

PRESSURE LOSS CALCULATION FORMULA

$$\Delta P = \left[\frac{Q}{Cv} \right]^2$$

ΔP = Pressure Drop

Q = Flow in GPM

Cv = Flow Coefficient

PRESSURE / TEMPERATURE CHART*

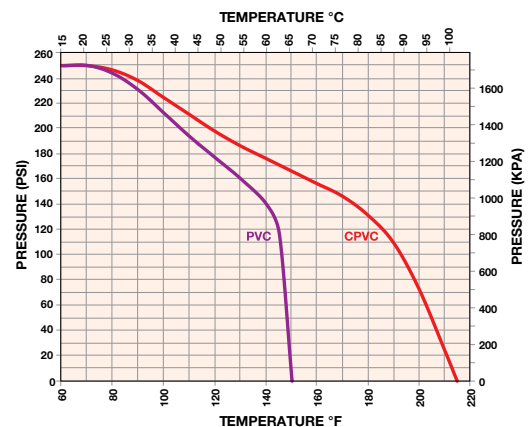

* Flanged valves rated to 150 PSI @ 70°F / 10 Bar @ 21°C Non-Shock



Hayward is a registered trademark of Hayward Industries, Inc. © 2023 Hayward Industries, Inc.

- Hastelloy is a registered trademark of Haynes International Inc.

NPP0823

Contact Hayward Flow Control with questions:

USA: 1.888.429.4635 • Fax: 1.888.778.8410 • One Hayward Industrial Drive • Clemmons, NC 27012 • Email: hflow@hayward.com

Canada: 1.888.238.7665 • Fax: 1.905.829.3636 • 2880 Plymouth Drive • Oakville, ON L6H 5R4 • Email: hflowcanada@hayward.com

Visit us at: haywardflowcontrol.com